

REINHOLD ENVIRONMENTAL Ltd.



**2013 Coal to Gas Conversion Round Table
& Expo Presentation**

October 29, 2013, in Chattanooga, TN / Sponsored by Southern Company

All presentations posted on this website are copyrighted by Reinhold Environmental, Ltd (RE). Any unauthorized downloading, attempts to modify or to incorporate into other presentations, link to other websites, or obtain copies for any other uses than the training of attendees to RE's Conferences is expressly prohibited, unless approved in writing by RE or the original presenter. RE does not assume any liability for the accuracy or contents of any materials contained in this library which were presented and/or created by persons who were not employees of RE.



power generation group

Coal to Gas Conversion
Boiler & Auxiliaries

October 29, 2013

Kevin Thomas
Proposal Manager

Boilers

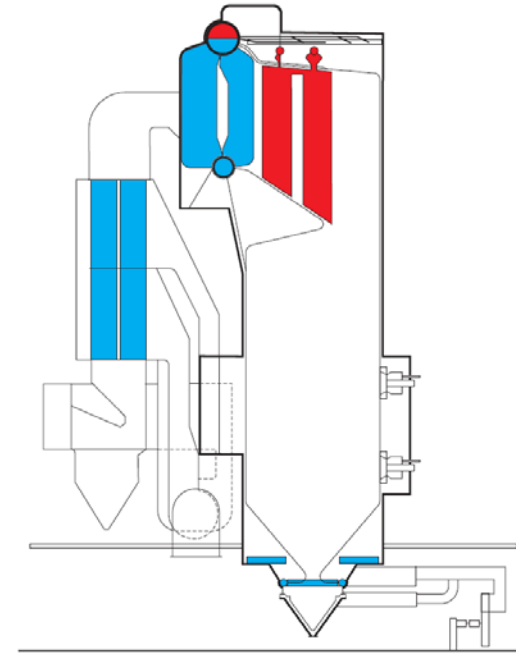
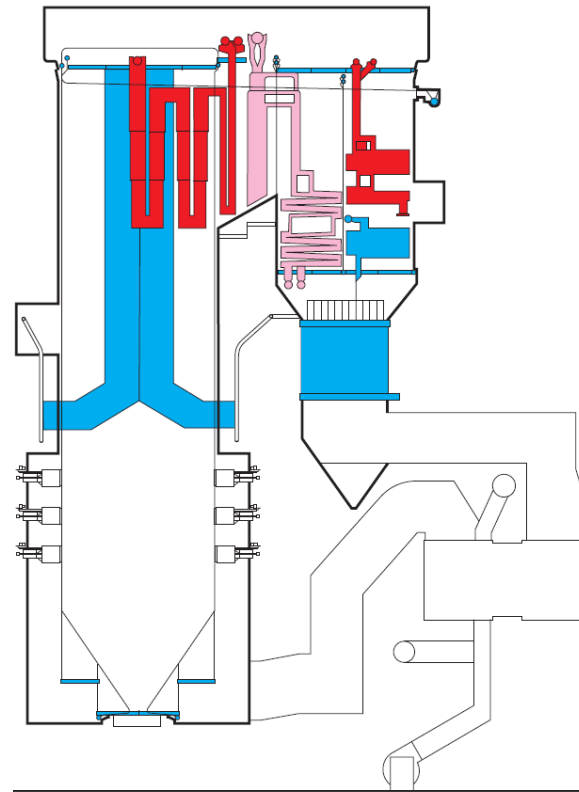
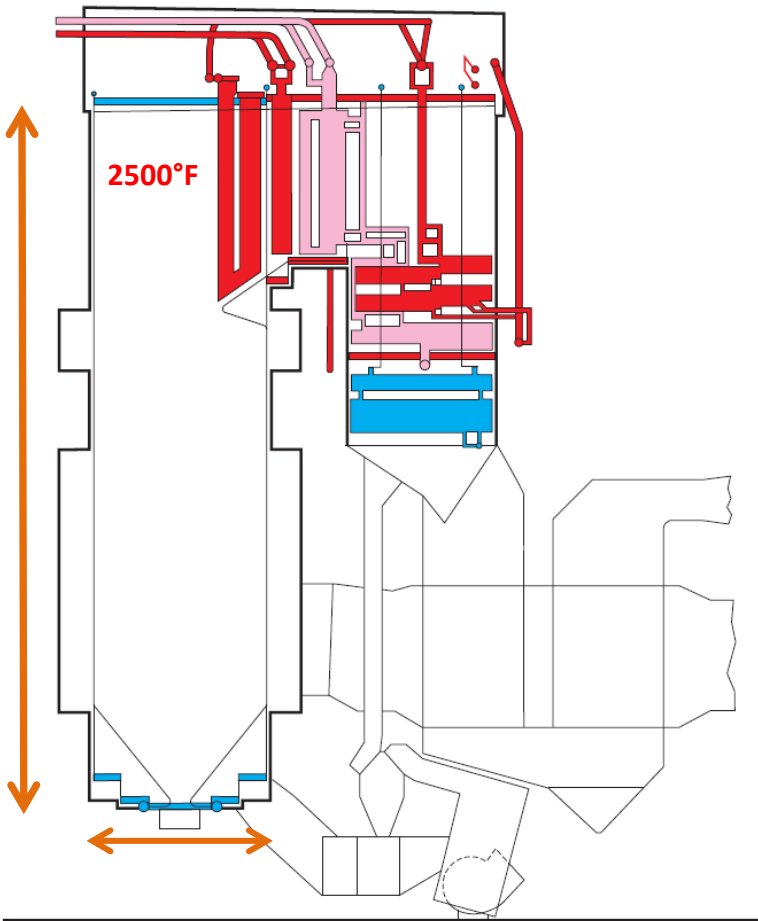

Natural Gas Conversion



Gas Conversion Fundamentals

So you want to
Convert this...

Into

This?

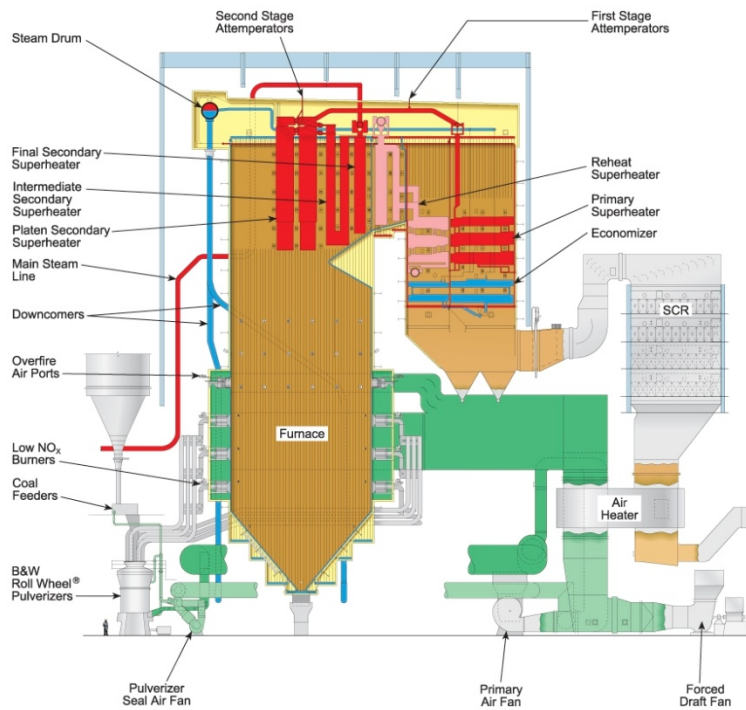

Typical PC Boiler

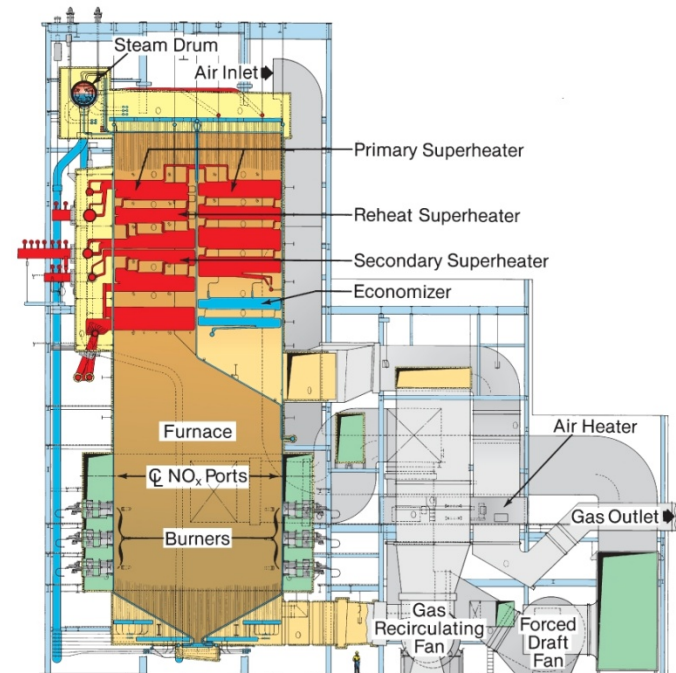

Typical Gas Boiler

Presentation Agenda

- a) Gas Conversion Fundamentals
- b) Emissions & Control Mechanisms
- c) Burner Options & Scope
- d) Fuel System Design
- e) Boiler Considerations
- f) Take Away Points
- g) Questions



Gas Conversion Fundamentals

Typical Fuel Analysis Comparison

Proximate (% by wt)	Bituminous	PRB	Natural Gas	
Moisture	3.5	27.22	90.0	CH ₃ (% by vol)
Volatile	35.7	29.90	5.0	C ₂ H ₆ (% by vol)
Fixed Carbon	51.8	37.17	5.0	N ₂ (% by vol)
Ash	9.0	5.71		
Ultimate (% by wt)				
Carbon	72.8	49.99	69.20	
Hydrogen	4.8	3.62	22.65	
Sulfur	2.2	0.33		
Oxygen	6.2	12.43		
Nitrogen	1.5	0.70	8.08	
Moisture	3.5	27.22		
Ash	9.0	5.71		
HHV (btu/lb)	13080	8772	21800	

Gas Conversion Fundamentals

Typical Flue Gas Property Comparison

@ constant excess air

% by wt.	Bituminous	PRB	Natural Gas
O ₂	2.92	2.80	2.98
CO ₂	21.34	21.42	13.01
N	70.48	67.59	72.41
H ₂ O	4.91	8.12	11.60
SO ₂	0.35	0.07	0.00
Specific Heat	0.272	0.278	0.286

Gas Conversion Fundamentals

Typical Efficiency Comparison

(Constant X-Air and AH Outlet Temps)

	Bituminous	PRB	Natural Gas
Losses (%)			
Dry Gas	4.82	4.78	4.20
Water from Fuel	4.07	7.83	10.62
Moist in Air	0.11	0.11	0.11
Unburned Combustible	0.30	0.15	0
Radiation	0.17	0.17	0.17
Unaccounted For	1.50	1.50	1.00
Total Losses	10.97	14.54	16.10
Boiler Efficiency	89.03	85.46	83.9

Gas Conversion Fundamentals

Other Performance Parameters

	Bituminous	PRB	Natural Gas
Fuel Input	Base	1.05x	1.08x
Air Wt.	Base	1.04x	0.98x
Gas Wt.	Base	1.08x	0.96x
FEGT	Base	+50-100F	+30F
Surface Effectiveness			
Furnace	Base	Base	1.08x
Convection	Base	(.8-.95)x	1.2x

NO_x Formation

Thermal NO_x:

- ▶ Formed by reaction between nitrogen and oxygen in the air
- ▶ Formation rate is function of temperature and residence time at high temperatures
- ▶ Accounts for majority of NO_x formation on natural gas firing

~~**Fuel NO_x:**~~

- ~~▶ Formed from combustion of fuels containing nitrogen~~
- ~~▶ Formation rate dependent on oxygen availability and fuel nitrogen content~~

Coal to NG Conversion

NO_x Formation and Control

Fuel Type



NO_x
(%)



Combustion Method

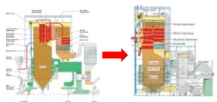
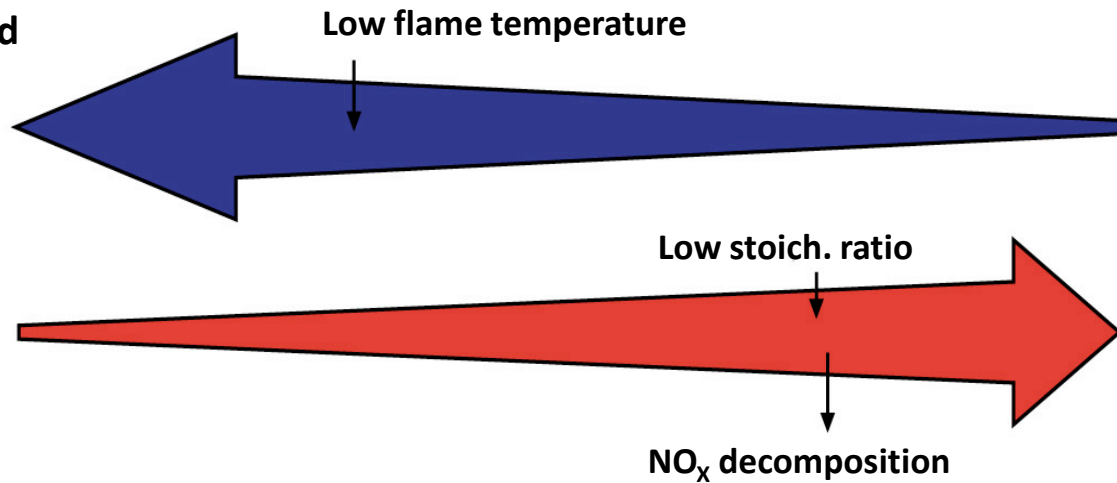

Coal to NG Conversion

NO_x Formation and Control

Thermal NO_x

- ▶ Dissociation & oxidation of nitrogen from combustion air
- ▶ Exponentially dependent on temperature, threshold ~2800°F
- ▶ Primary mechanism for NO_x formation from natural gas

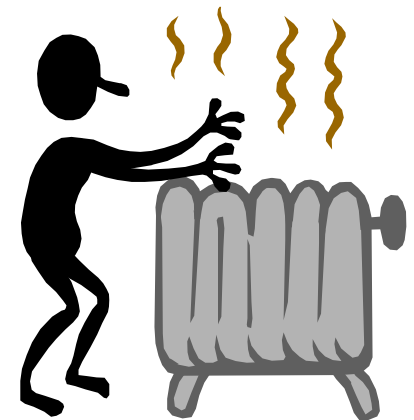
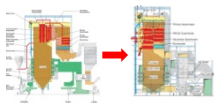

Coal to NG Conversion

NO_x Formation and Control

Thermal NO_x Control Strategies

- ~~Burner Zone Release Rate~~
 - ~~Increase heat absorption in burner zone to decrease temperature by modification to burner arrangement/spacing~~
- **Combustion System Design**
 - Staged combustion to reduce combustion rate by delayed introduction of combustion air
 - Controlled mixing in burners to reduce combustion rate
- **Gas Recirculation to Windbox**
 - Forced FGR
 - Induced FGR

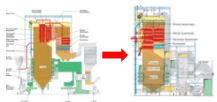

Coal to NG Conversion OFA System

- Diverts a portion of the combustion air to ports located above the burners
- Burner peak flame temperatures are lowered
- Heat is released over more furnace area

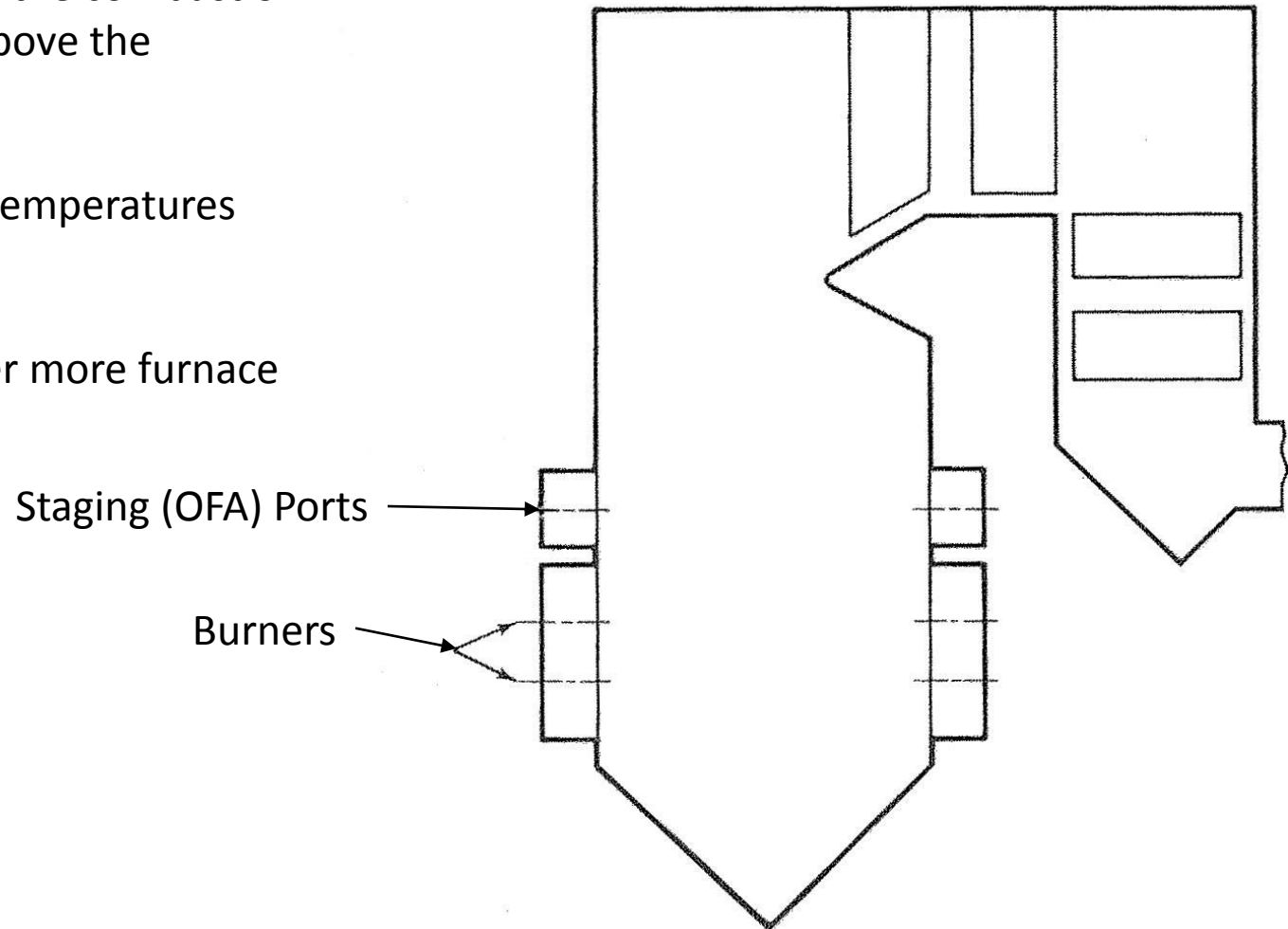

Coal to NG Conversion

FGR System

- Flue Gas Recirculation (FGR) to the burners is instrumental in reducing NO_x emissions when firing natural gas.
- Forced FGR vs. Induced FGR
- Burner peak flame temperatures are lowered
- Installing OFA ports in conjunction with FGR serves two useful purposes:
 - 1) Lower NO_x emissions through two-stage combustion
 - 2) A decrease in mass flow of air to the burners to accommodate the increased burden of recirculated flue gas.

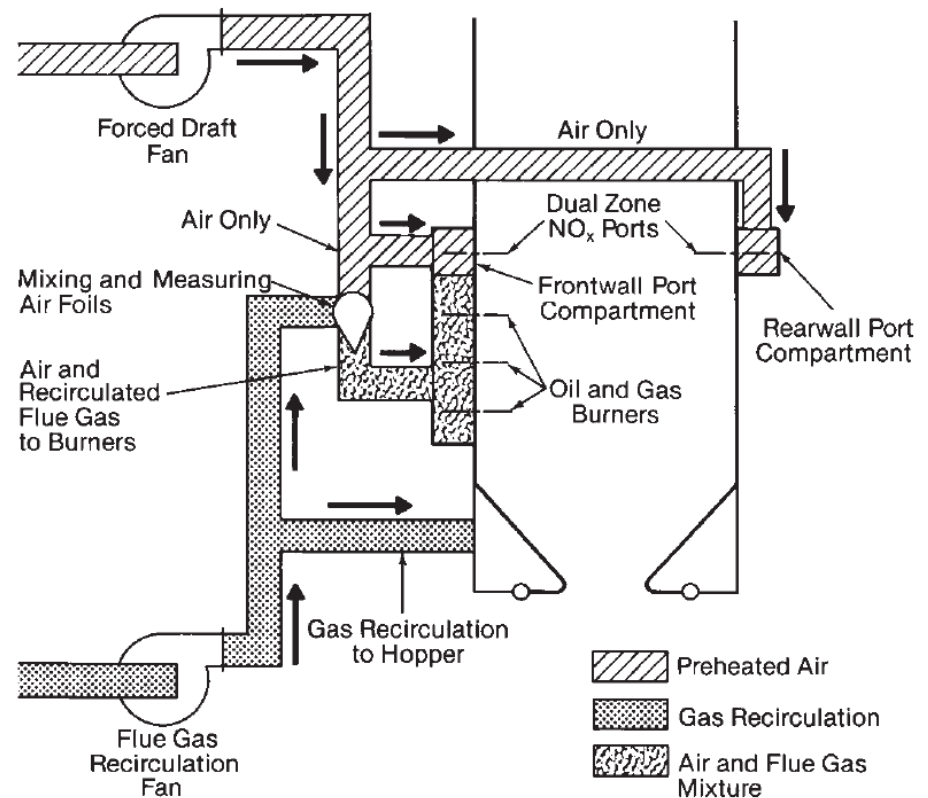

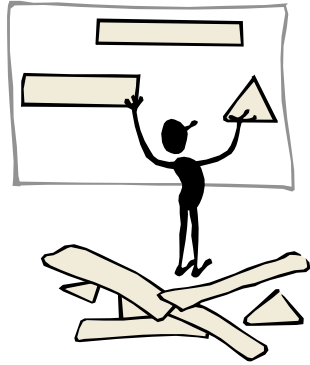

Coal to NG Conversion Burner Options

For coal fired boilers there are **four** approaches depending on the owner's objectives

1. Completely abandon coal – Replace all burners with new gas burners
2. Retain ability to fire coal – Modify existing coal burners with gas elements
3. Retain ability to fire coal – New dual fuel burners (PC/NG)
4. Continue to fire coal – Partial burner replacement/modification

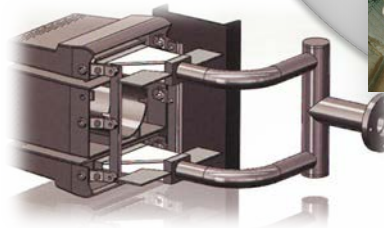
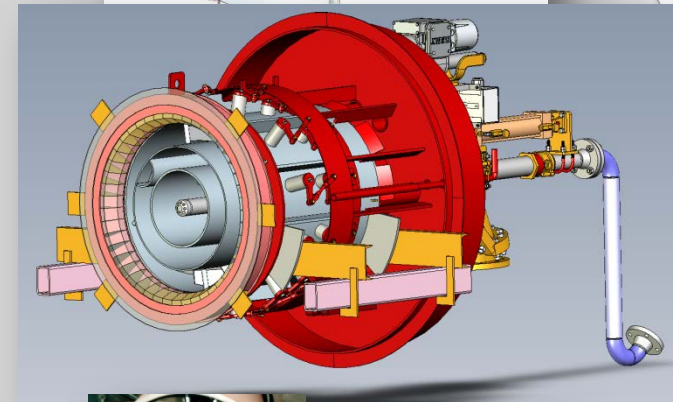
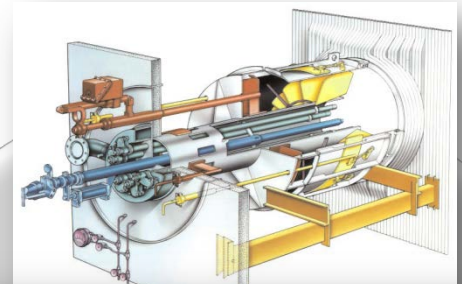

Coal to NG Conversion

Approach 1 – Abandon Coal – New NG Burners

- Complete Burner replacement with new gas only burners
- Highest cost & longest outage time
- Allows for best combustion and boiler performance

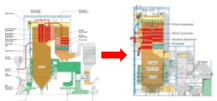
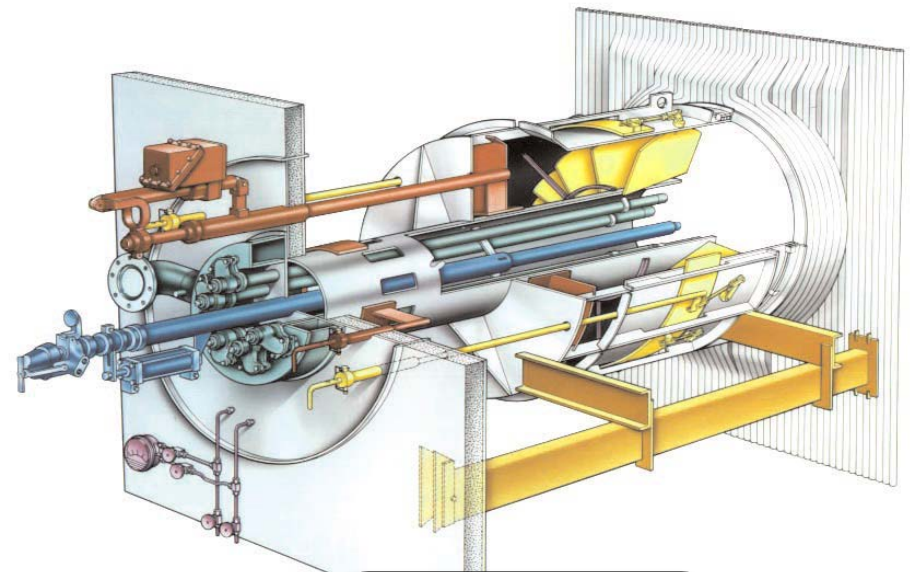

Coal to NG Conversion

Approach 2 – Continue Coal – Gas Element to Existing Coal Burner

Where a unit is already equipped with PC burners, burner modifications can be supplied incorporating a gas element

- Lower cost & shorter outage time
- Performance compromises
- Can modify all or some burners

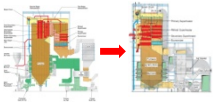
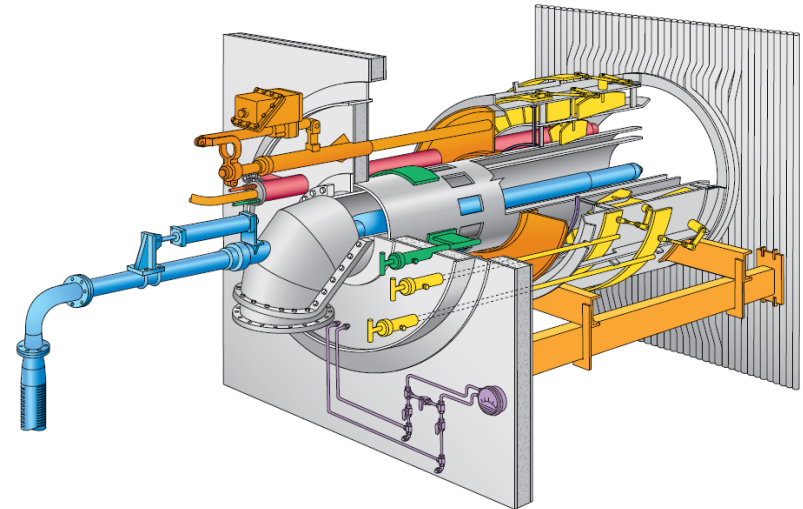

Coal to NG Conversion

Approach 3 – Retain Coal – PC/Gas Burner Replacement

Where existing burners are not suitable for a simple modifications, a complete PC burner with gas element(s) can replace existing burners

- Higher cost & longer outage time
- Allows for good compromise between fuel flexibility and combustion performance
- Burners can be sized for reasonable pressure drop and/or to accommodate FGR

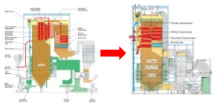
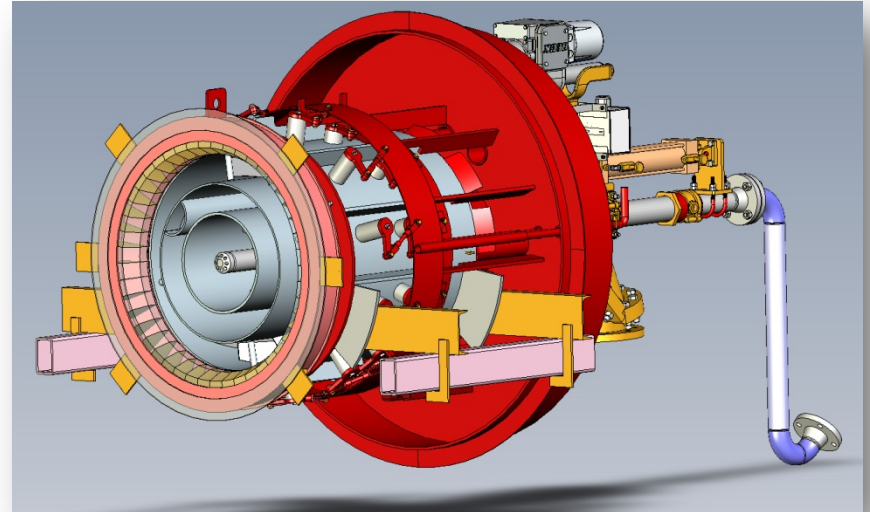

Coal to NG Conversion

Approach 4 – Retain Coal – Augment / Partial Replacement

In some cases where an owner plans to continue to fire coal but would like to augment with gas to lower emissions or improve turndown, some burners can be replaced or modified for gas firing

- More applicable to larger units ($\geq 250\text{MW}$)
- Good tool for turndown improvement
- Can be coupled with change to gas ignitors for incremental increase in heat input on gas

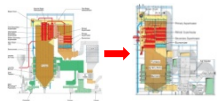
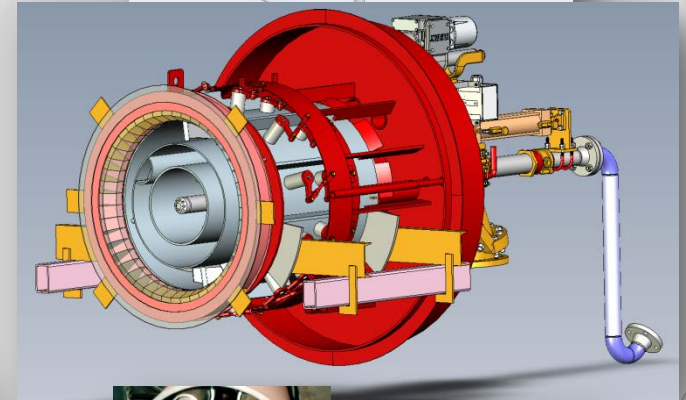
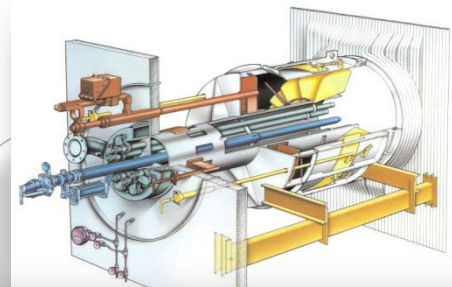

Natural Gas Conversion Burner Front Scope Items

- **New Burners / Burner Modifications**
- **Natural Gas Igniters**
 - **Class I** – Fueled ignitor generally in excess of 10% of full load burner input
 - **Class III** – Fueled ignitor with a capacity that generally does not exceed 4% of the full load burner fuel input
 - **Class III Special Igniter** – High energy electrical igniter capable of directly igniting the main burner fuel
- **Scanners**
 - Ultraviolet Spectrum
 - Sighting – (direct view or fiber optic extension) to insure flame discrimination
 - FGR - flame color
- **Blower Skid**
 - Adequate cooling air flow to scanners
 - Cooling and combustion air to igniters
- **FGR or IFGR system**
 - depending on NOx performance level desired
- **OFA system**
 - depending on NOx performance level desired



Natural Gas Conversion Burner Front Scope Items

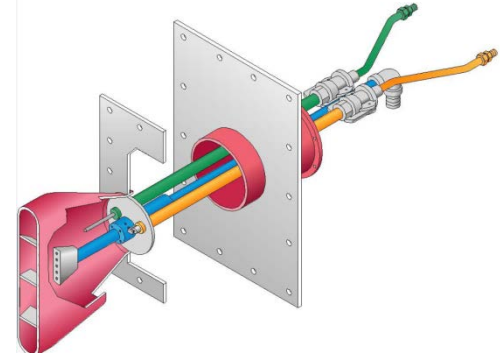
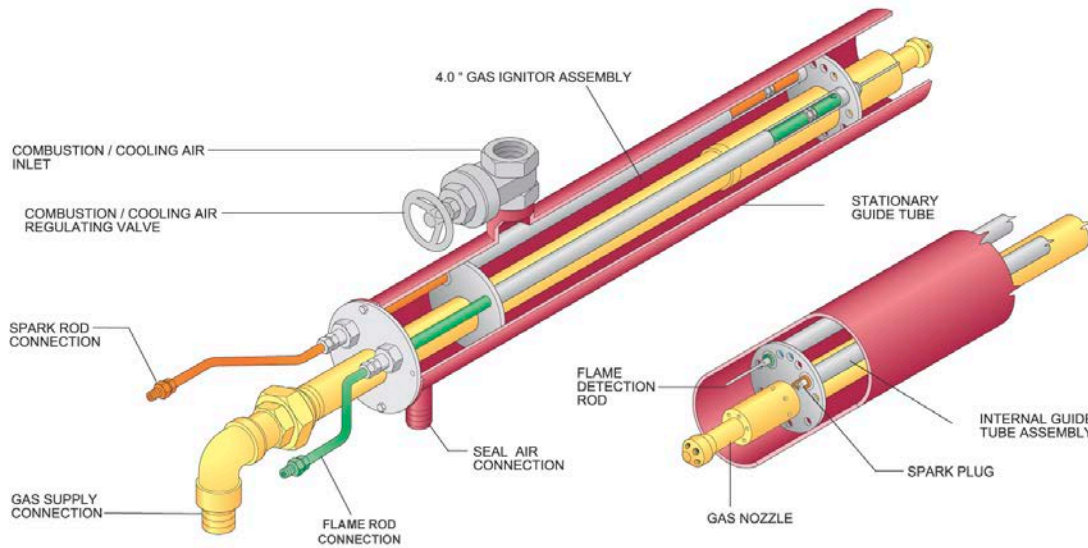

Gas Igniters

Scanners

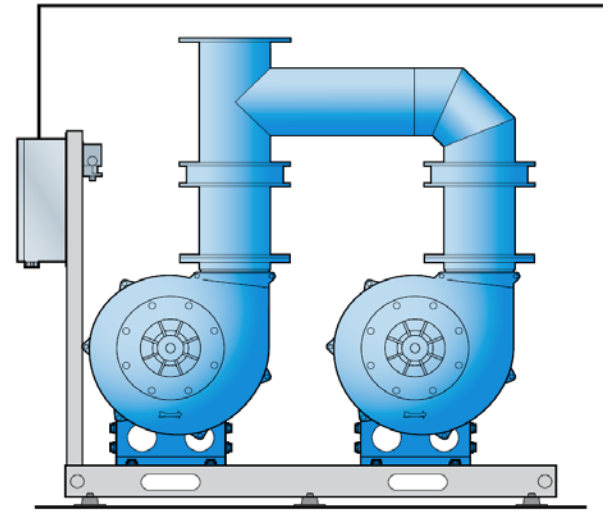

Duplex Blower Skid

Natural Gas Conversion Burner Front Scope Items

• Air Piping

- Blower Skid to the Scanners/Ignitors
- Piping can be supplied loose for field fabrication with loose fittings and come coated with weld-able prime paint
- Piping can be shop fabricated in spool pieces for ease of installation

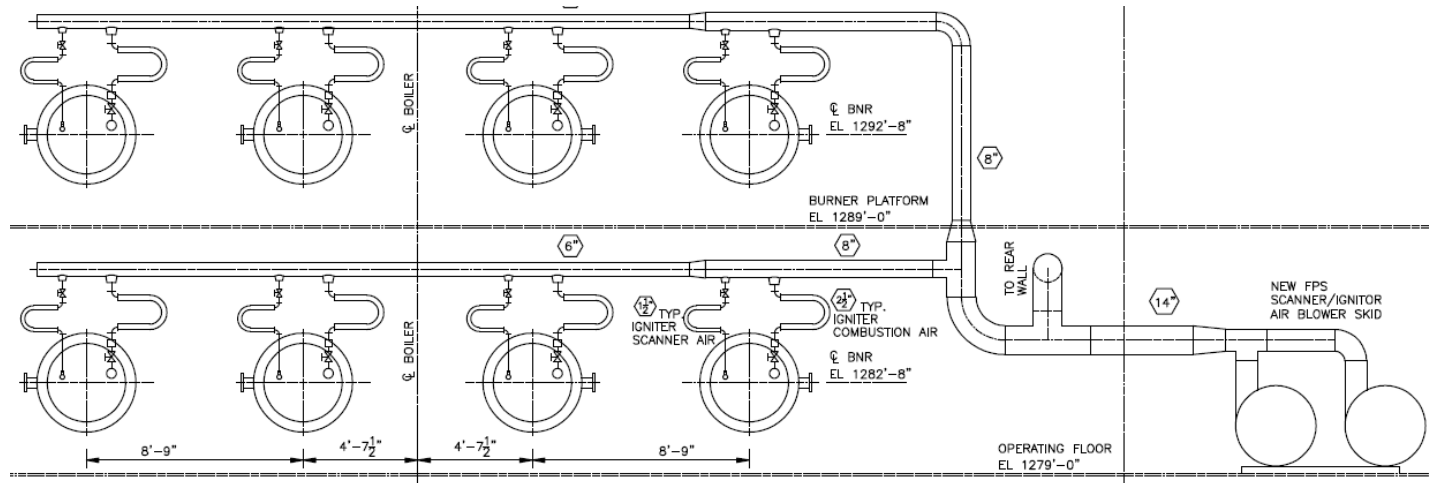

Natural Gas Conversion

Gas Supply - Fuel System



- **Natural Gas - Quality**

- **Interstate Pipeline Quality Gas**

- Conditioned
- Dehydrated to a maximum water content (7 lbs water / Mscfh of gas)
 - Typical 5-7 lbs/Mscfh
- Treated to remove any traces of hydrogen sulfide

- **Regional Gas**

- Often not treated at all
 - Arrives saturated and with whatever sulfur content inherent in that well

Natural Gas Conversion

Gas Supply - Fuel System

- Natural Gas Concerns

- **Water content in the gas**

A plant owner wants to ask of their gas supplier includes:

1. Water content in lbs/Mscfh
2. Gas Pressure at owners terminal point
3. Flowing gas temperature at owners terminal point
4. Hydrogen sulfide content in ppm

With these parameters, dew point can be calculated and the need for a gas heater determined for the various pressure reduction stages.

- **Exterior piping corrosion**

- Plant owners in geographical areas where high relative humidity is present
- Even though gas temp might be well above its dew point, it will very often be below the ambient air dew point
- Substantial amounts of condensate will form on piping

Special pipe coating system can be used to mitigate this effect or thermal pipe insulation.

Natural Gas Conversion

Gas Supply - Fuel System

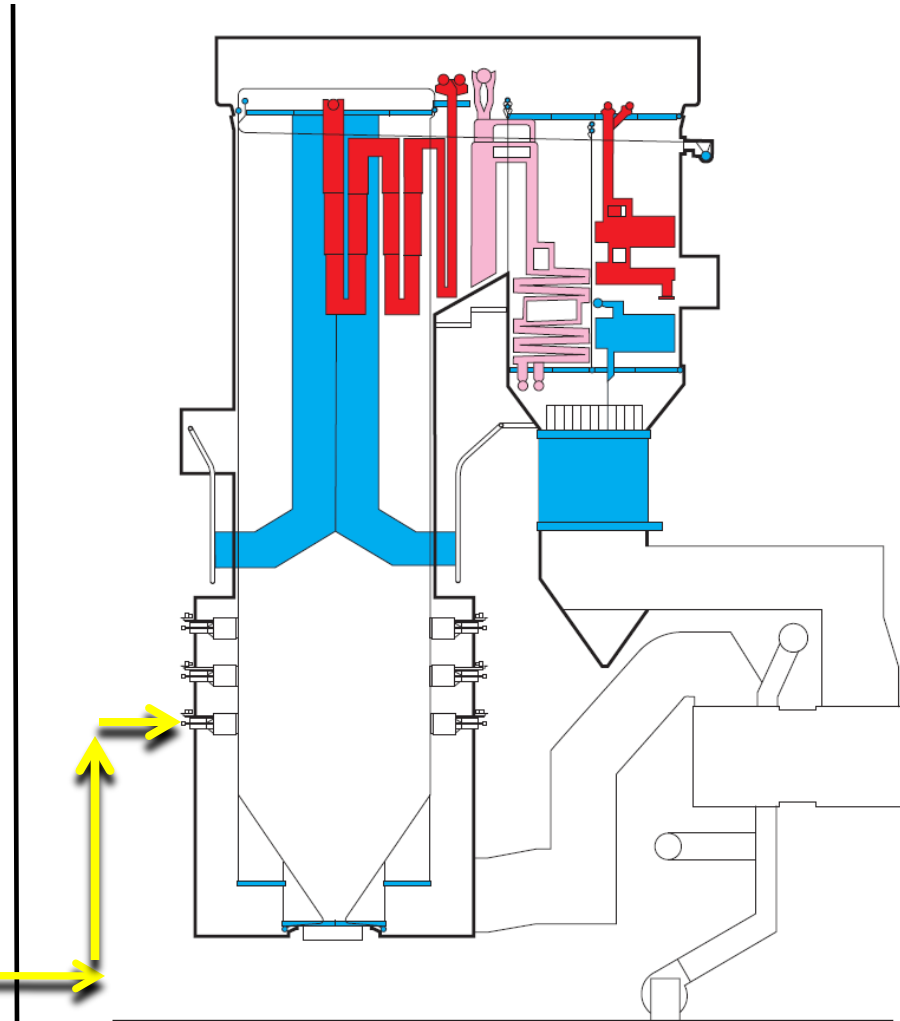
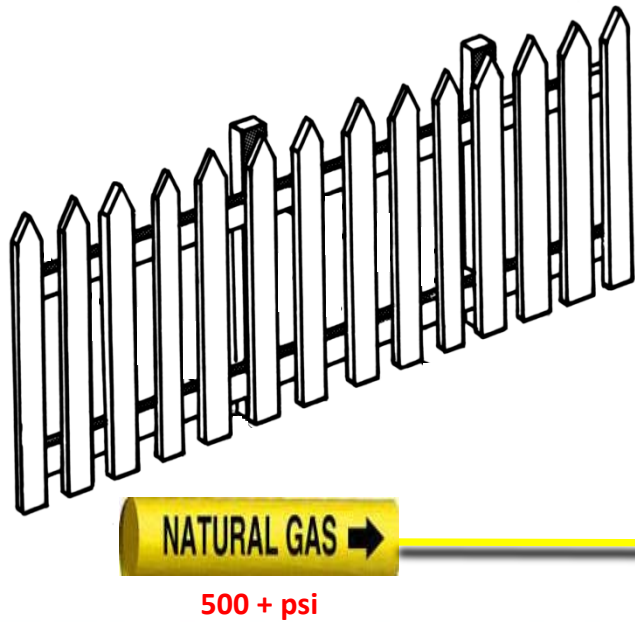

Natural Gas Conversion

Gas Supply - Fuel System

- Gas Pressure Reducing and Protection Station
- Burner & Igniter Natural Gas Supply Header Station
(Man Shut-off VLVs, BNR SSV, Charging SSV, Flow Ctrl VLV)
- Local Burner & Igniter Valve Racks
(double block & vent valves)
- Fuel and Vent Piping

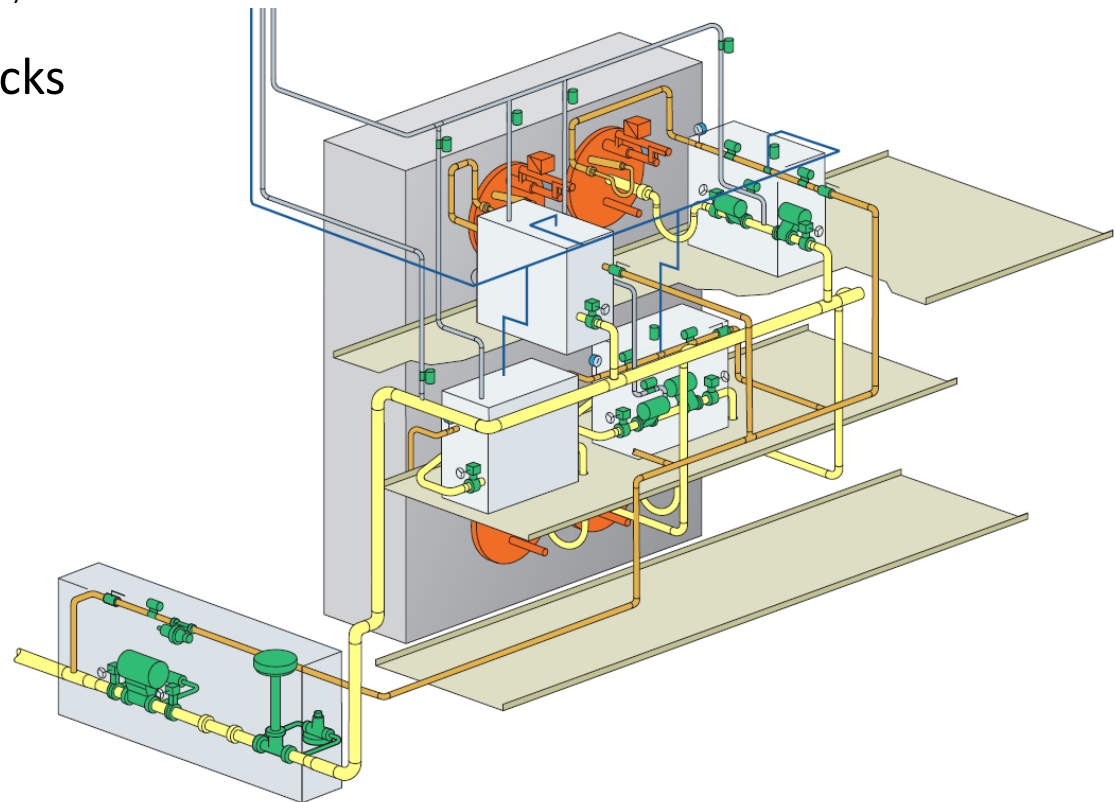

Natural Gas Conversion Gas Supply - Fuel System

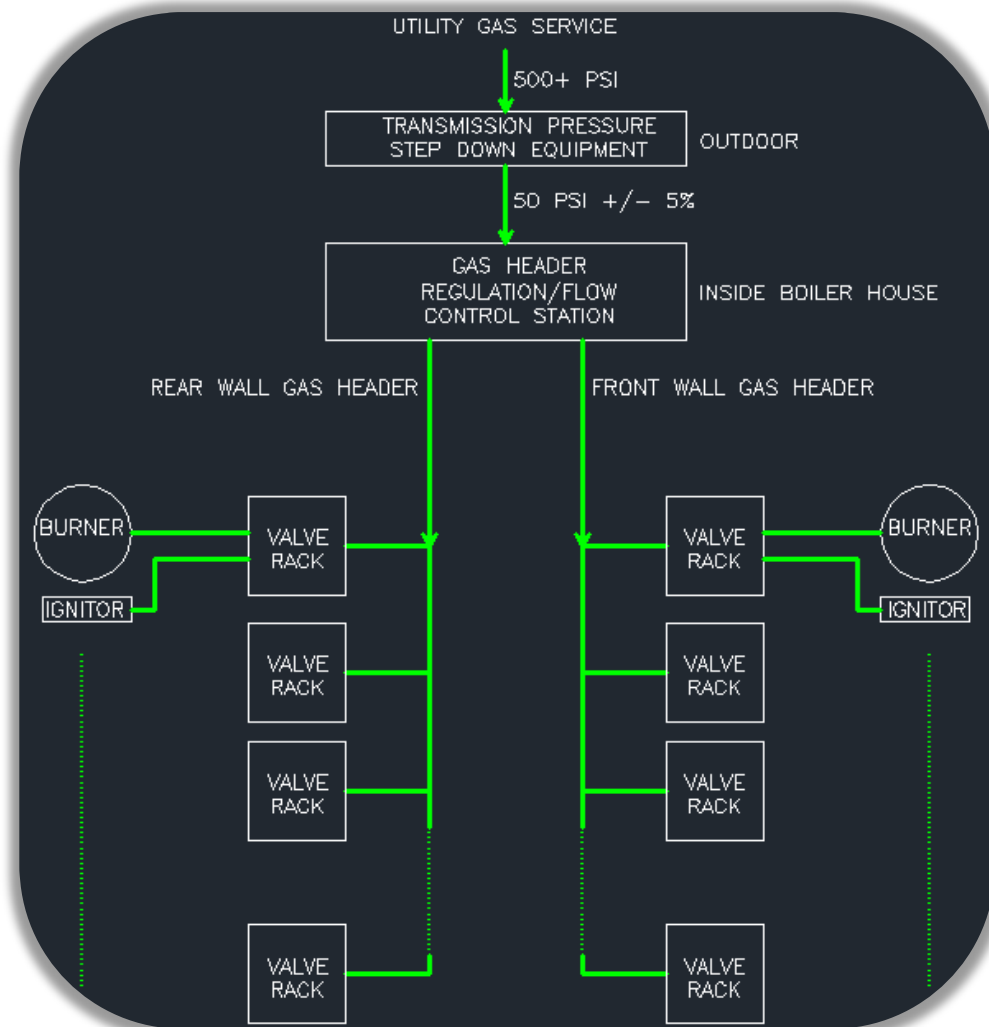

Natural Gas Conversion Gas Supply - Fuel System

Gas Pressure Reducing & Protection Station

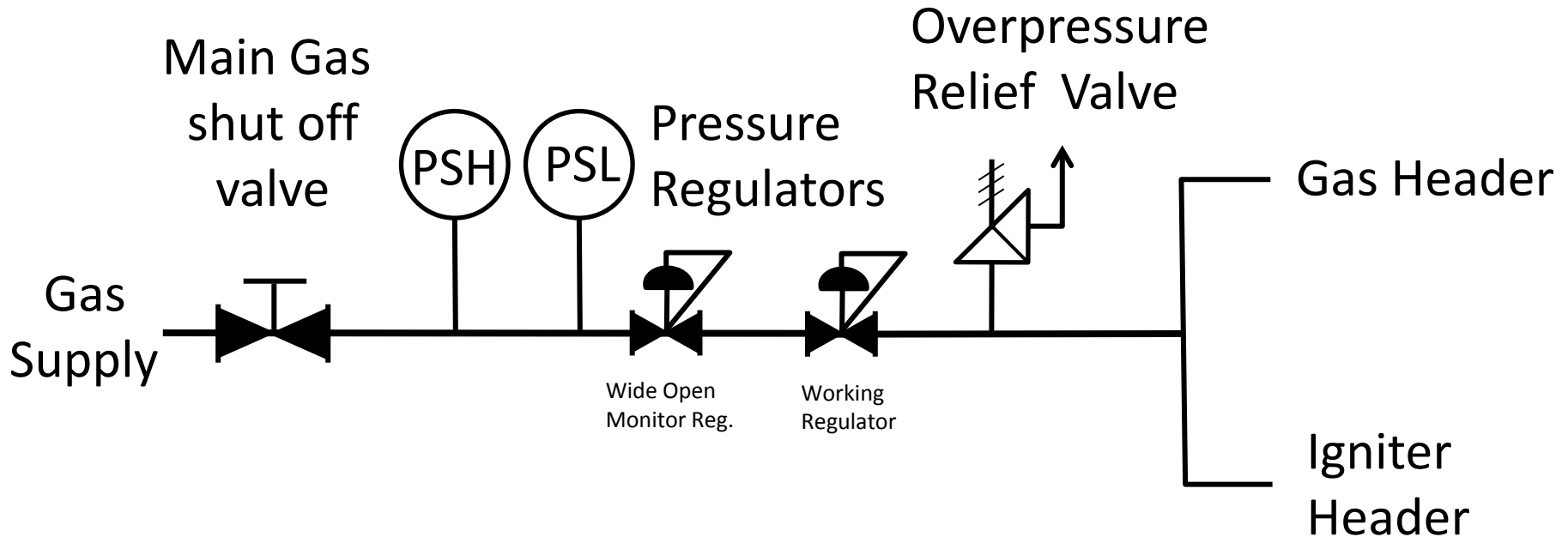

Natural Gas Conversion Gas Supply - Fuel System

Burner Gas Header

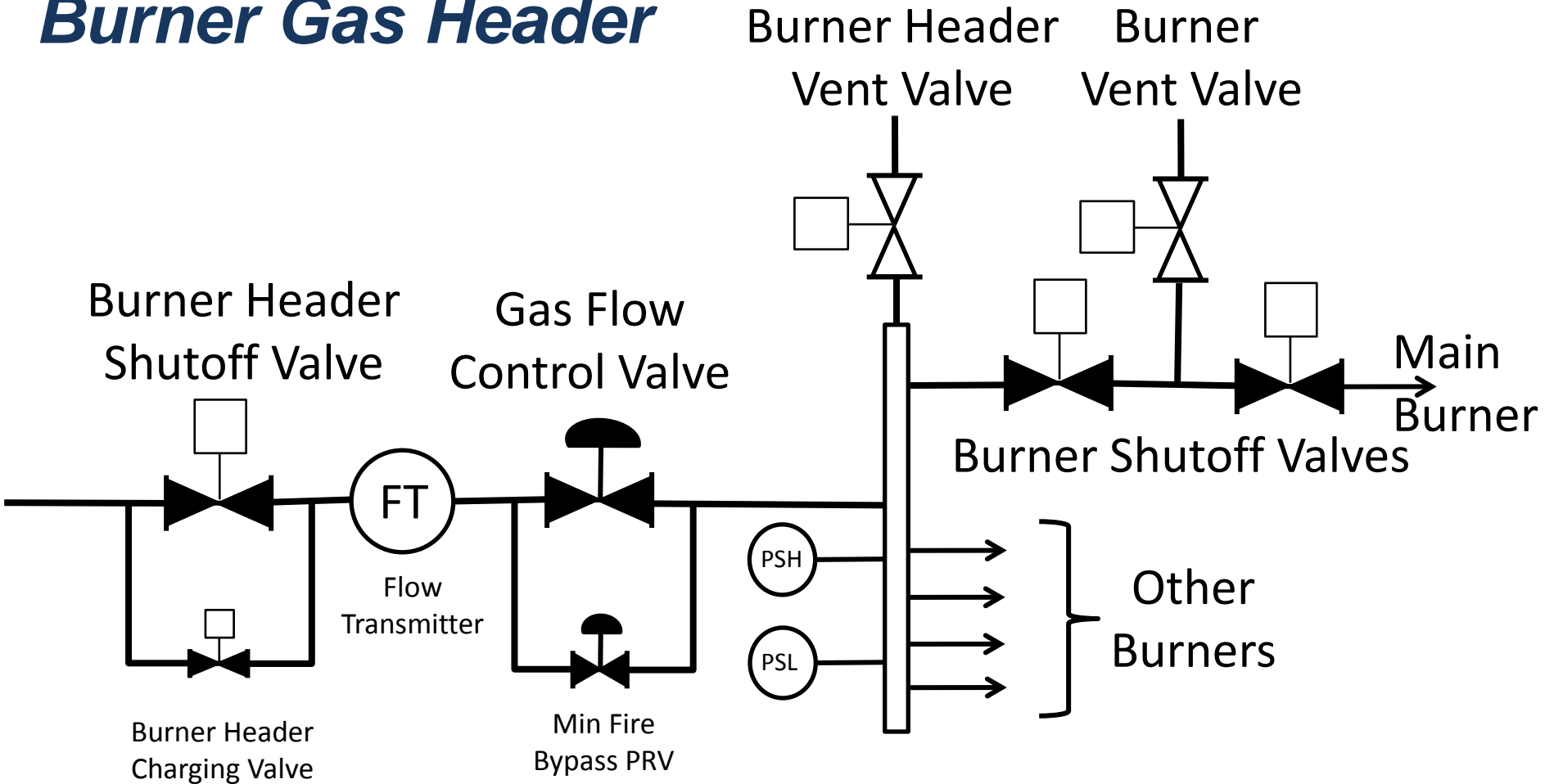

Natural Gas Conversion Gas Supply - Fuel System

Igniter Gas Header

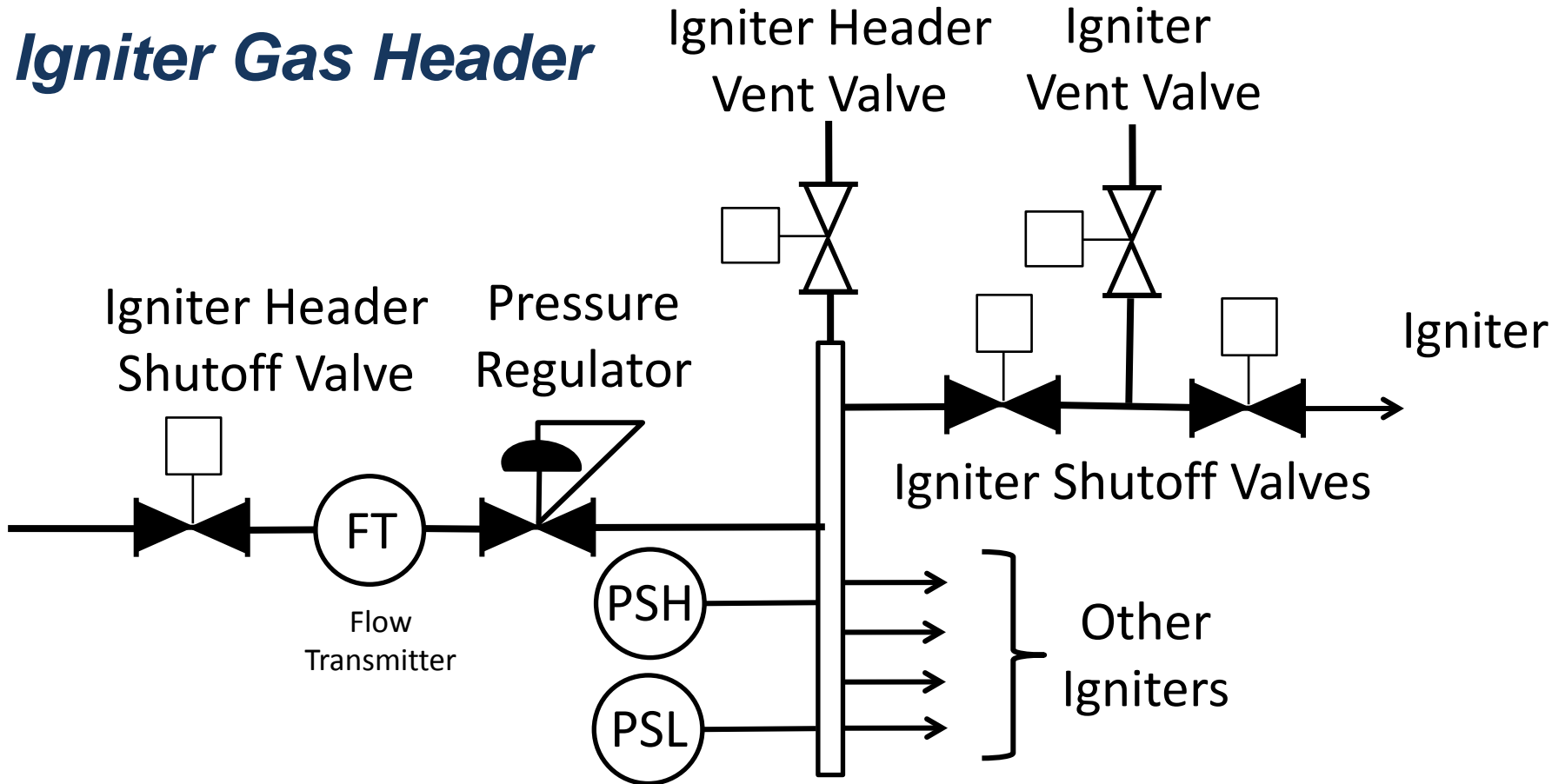

Natural Gas Conversion Gas Supply - Fuel System

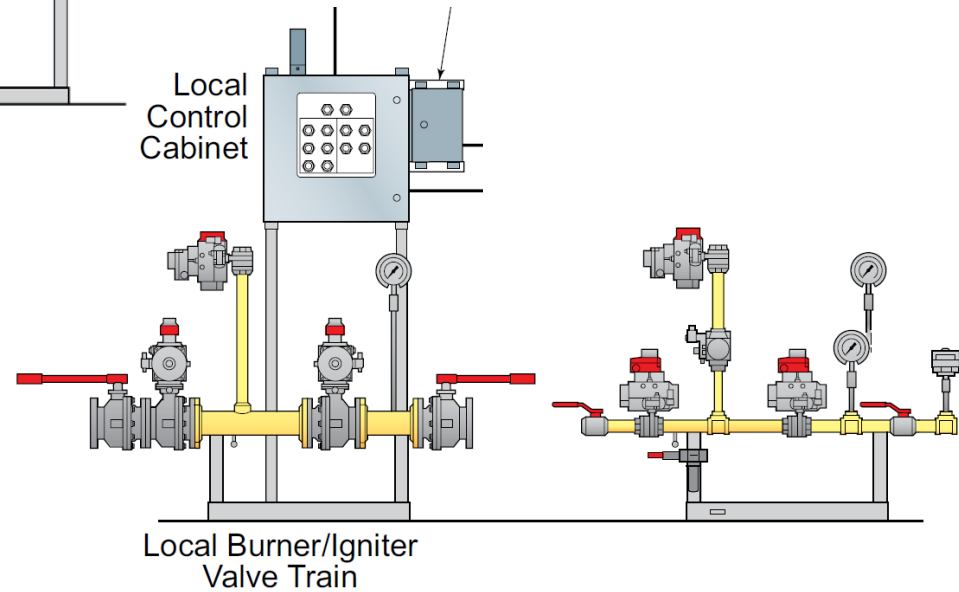
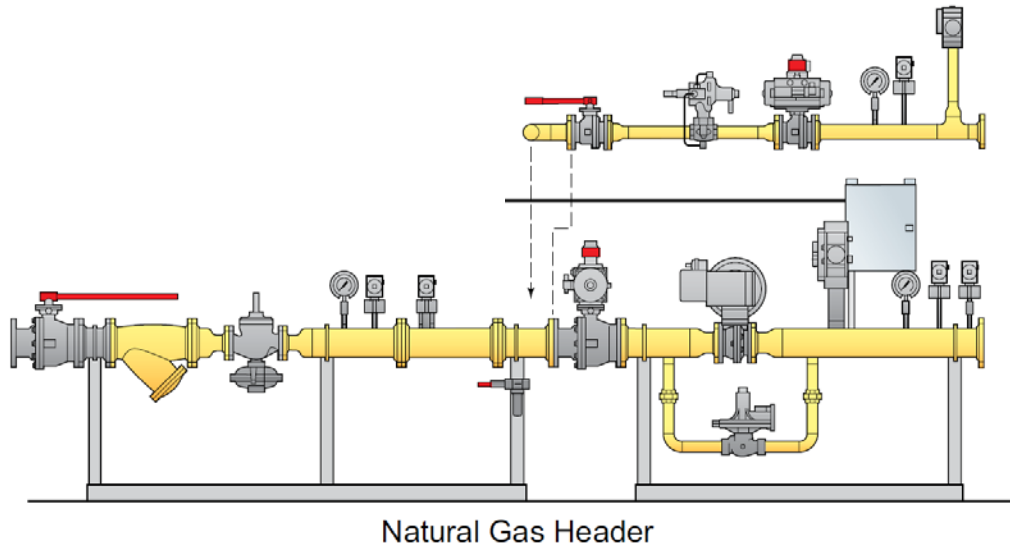

Natural Gas Conversion Gas Supply - Fuel System

Venting

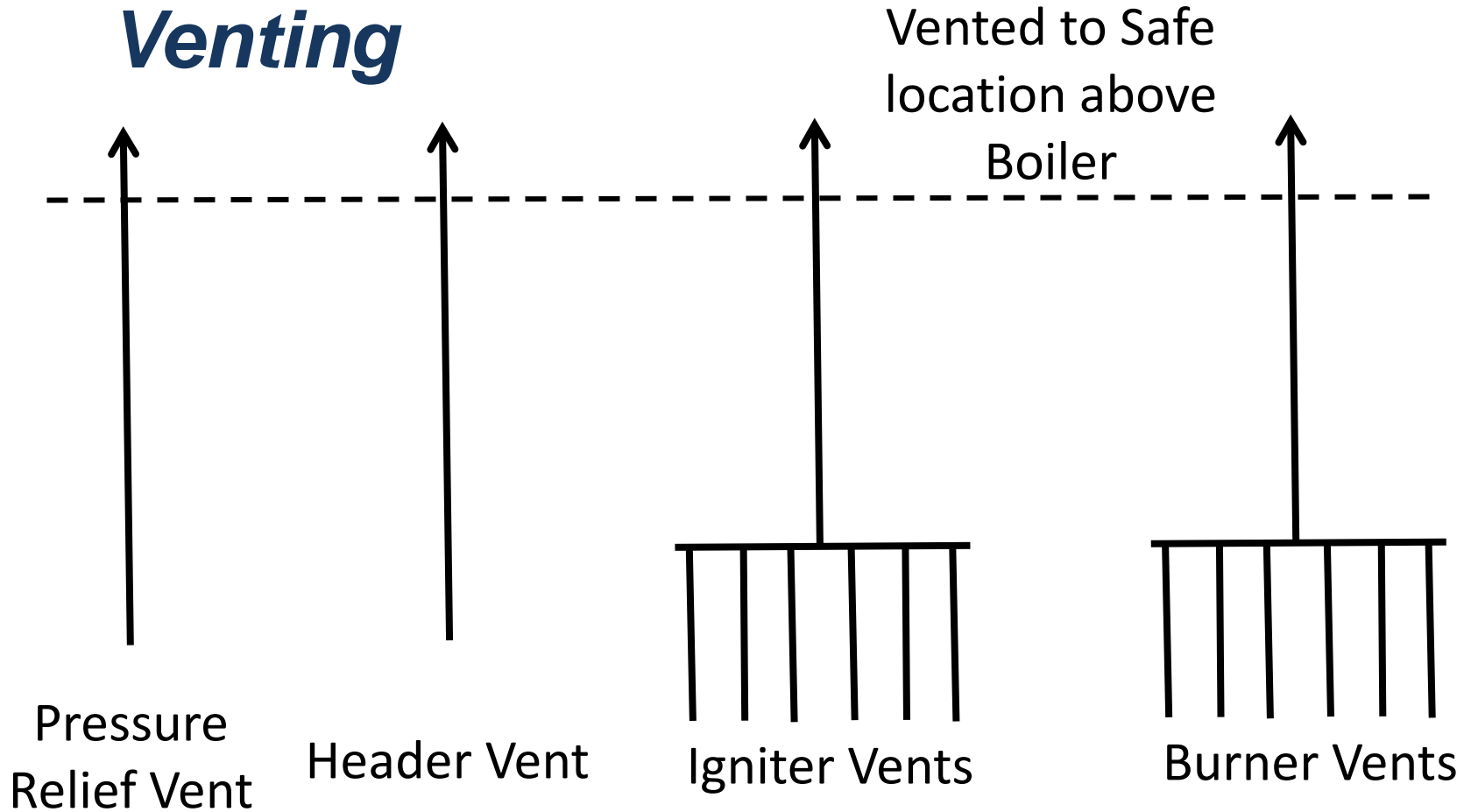

Natural Gas Conversion Boiler Considerations

- Convection Pass Pressure Parts
- Steam Temperature Control
- Air System

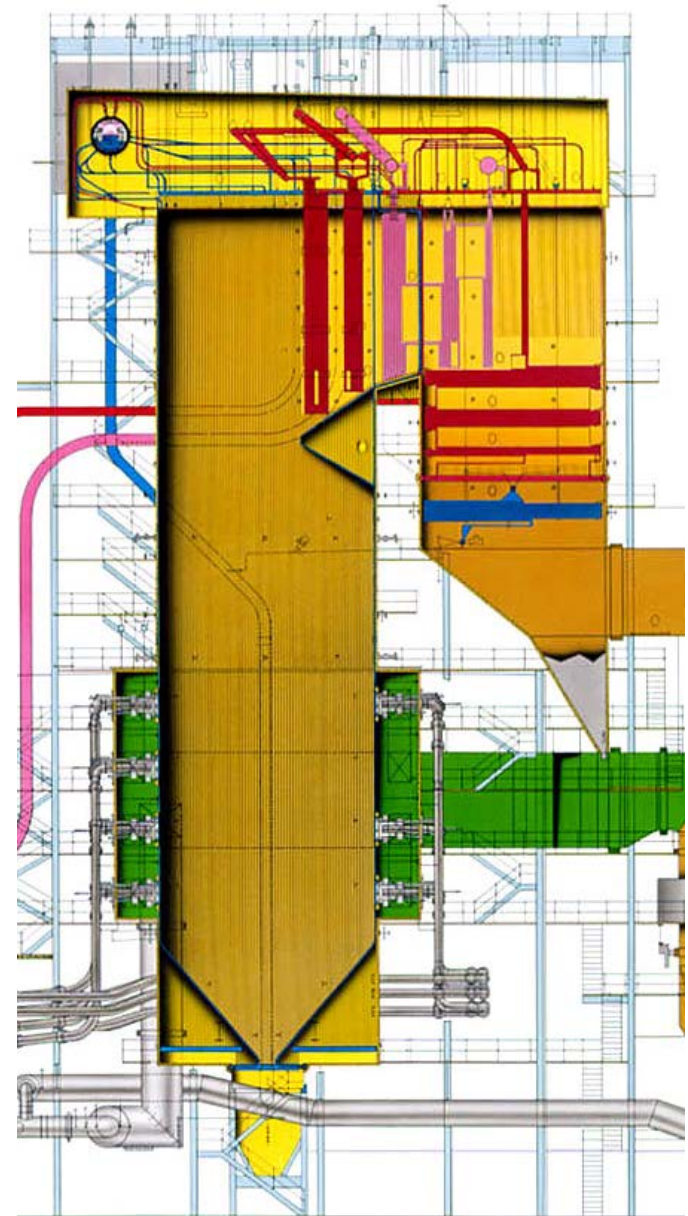

Natural Gas Conversion

Boiler Considerations – Steam Temp Control

Two Design Approaches for Steam Temperature Control:

- **Wall Firing, Fixed Burners – B&W, FW, Babcock Power (Riley)**

- Steam Temperature Controlled by:
 - Attemperation
 - Gas Biasing (parallel downpass)
 - Excess Air
 - Gas Recirculation

- **Corner Firing, Tilting Burners – Alstom (CE)**

- Steam Temperature Controlled by:
 - Burner Tilts
 - Attemperation
 - Gas Recirculation

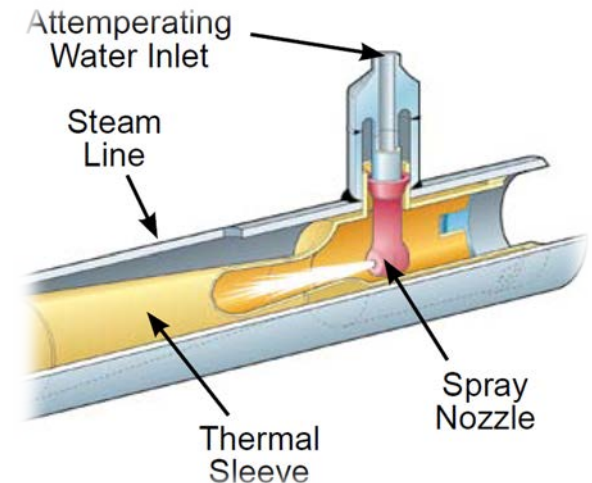

Natural Gas Conversion

Boiler Considerations – Pressure Parts

Pressure Parts:

- ▶ Radiant SH & RH surface absorptions are lower due to flue gas properties
- ▶ Convective surface absorptions are higher due to gas weight, gas properties and surface effectiveness
- ▶ Spray attemperator capacities need to be checked
- ▶ PSH, SSH and RH outlet sections often require surface adjustments and/or materials upgrades
- ▶ PSH outlet headers sometimes need to be upgraded
- ▶ Economizer surface may need to be modified to prevent steaming

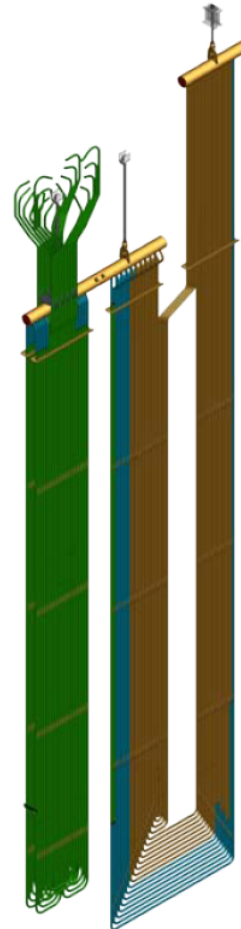

HEAT TRANSFER PROPERTIES		
	Coal	Gas
Radiant	↑	↓
Convective	↓	↑

Convection Pass Pressure Parts

- Material upgrades may be necessary because gas firing can overstress tubes
- More than 145 years of boiler design experience combined with proprietary boiler performance modeling allows us to provide a superior engineered solution for your unique application

Natural Gas Conversion Boiler Considerations – Air Systems

There are several configurations of Primary/Secondary
Air Systems

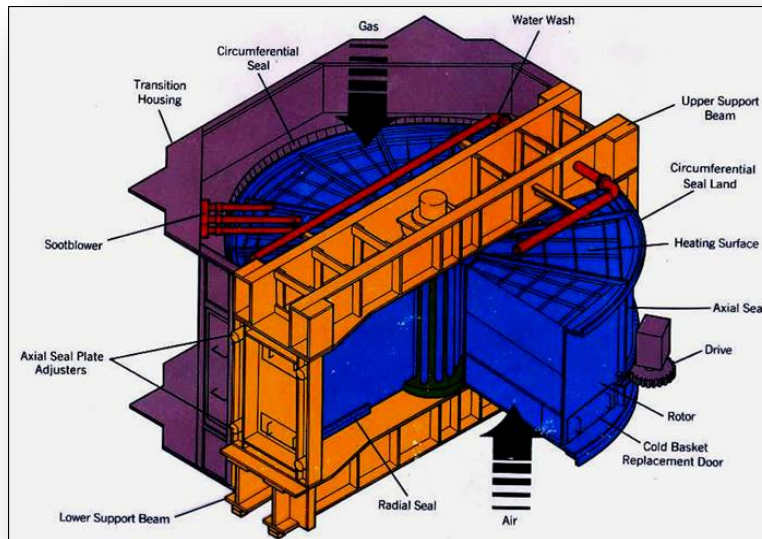

Natural Gas Conversion Boiler Considerations – Air Systems

HOT Primary Air System

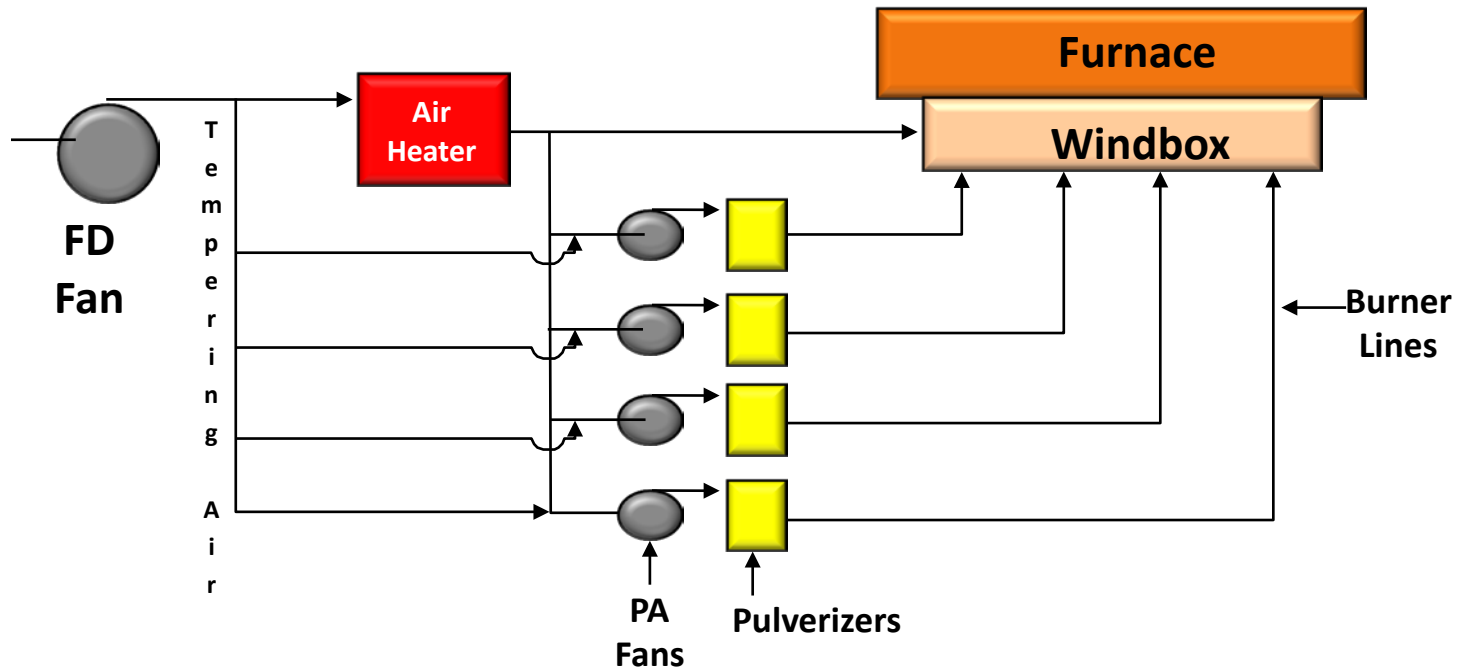

Natural Gas Conversion Boiler Considerations – Air Systems

HOT Primary Air System - after NG Conversion

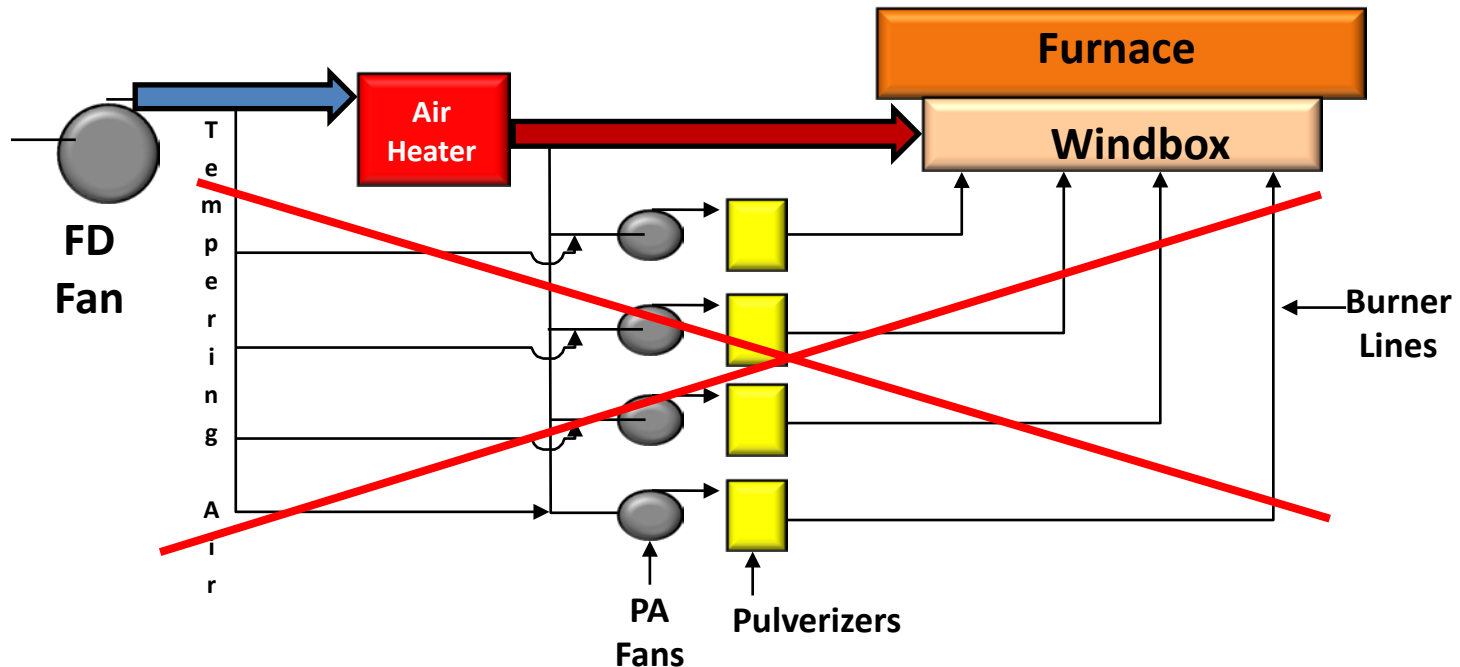

Natural Gas Conversion Boiler Considerations – Air Systems

COLD Primary Air System

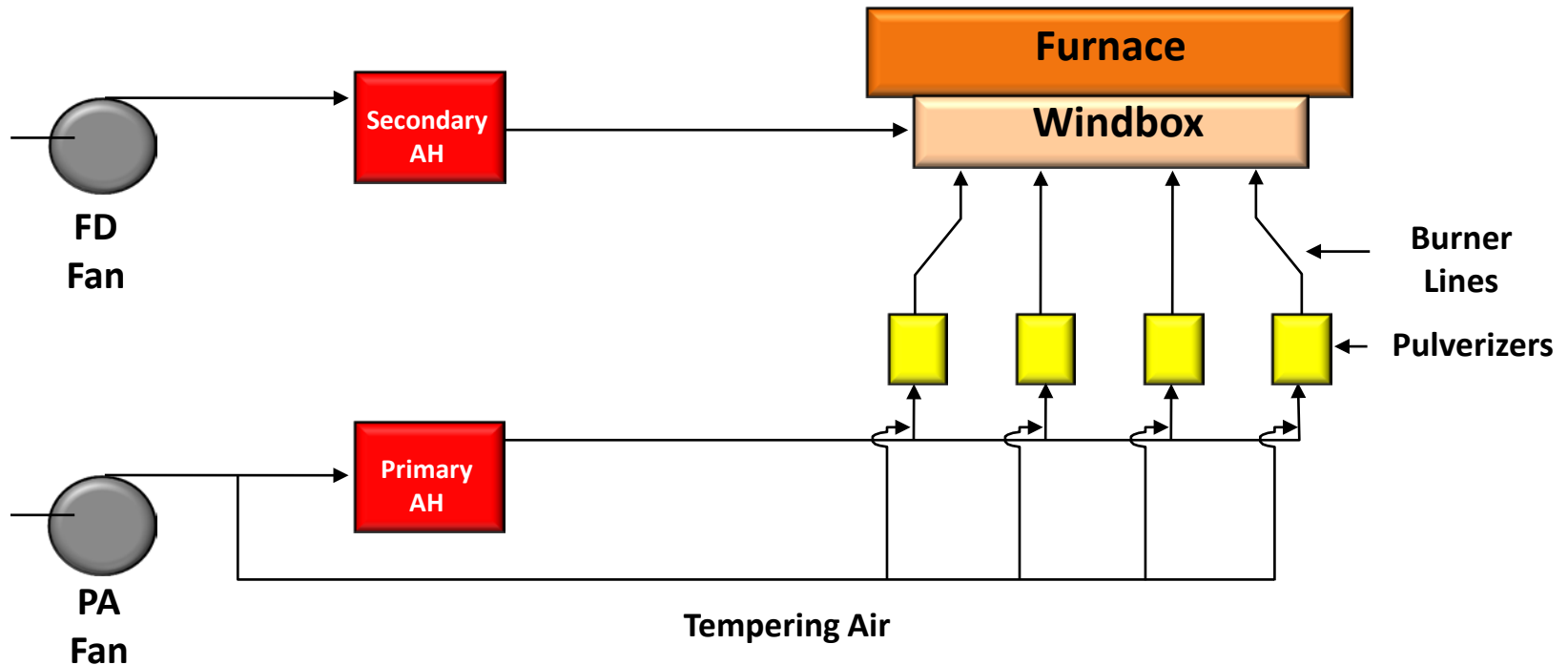

Natural Gas Conversion Boiler Considerations – Air Systems

COLD Primary Air System – after NG Conversion

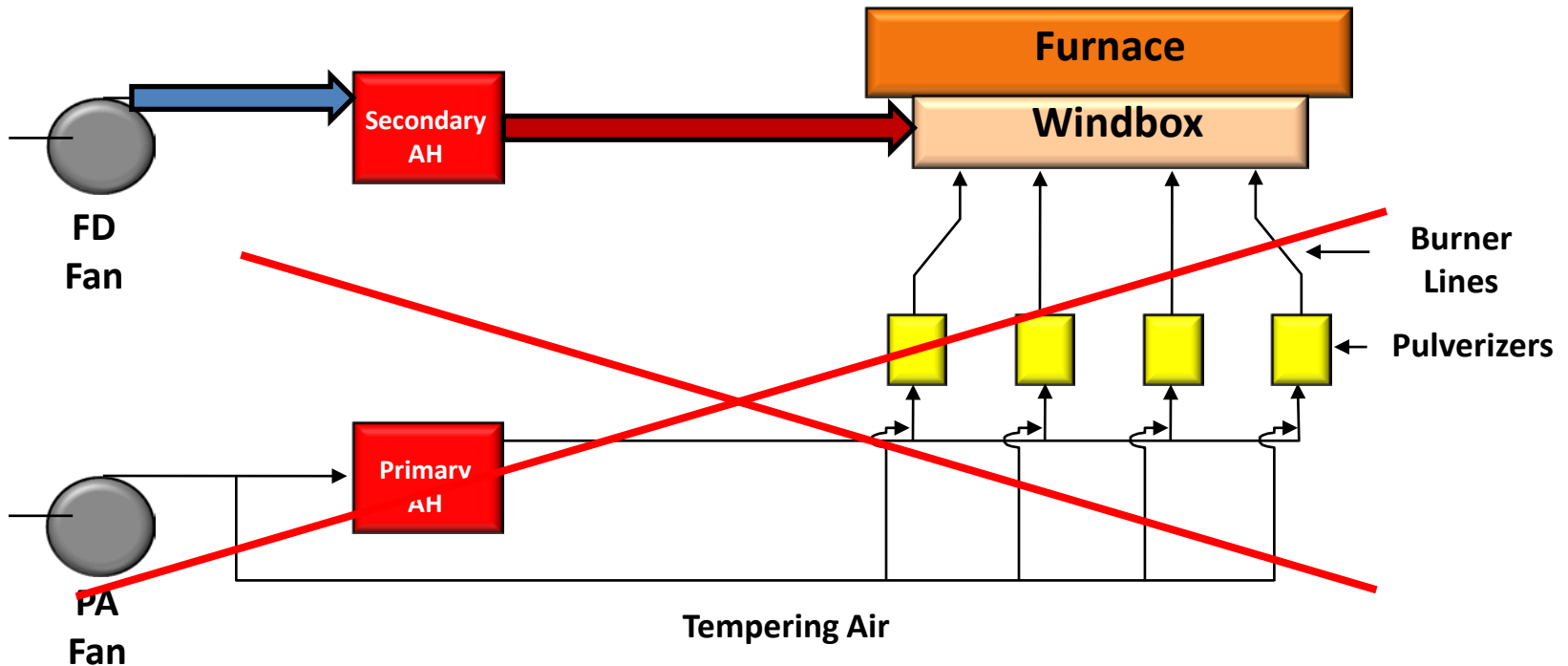

Natural Gas Conversion Boiler Considerations – Air Systems

Boosted Primary Air System

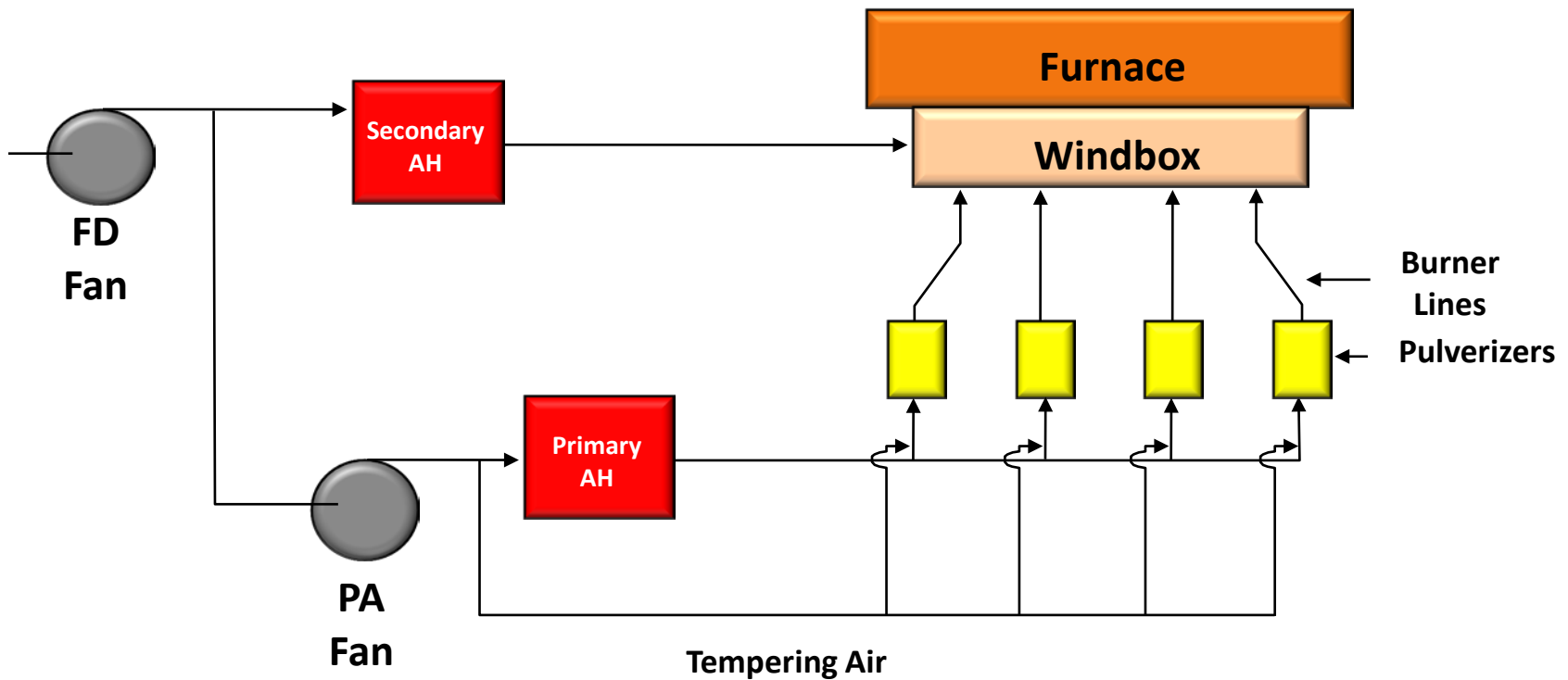

Natural Gas Conversion Boiler Considerations – Air Systems

Boosted Primary Air System – after NG Conversion

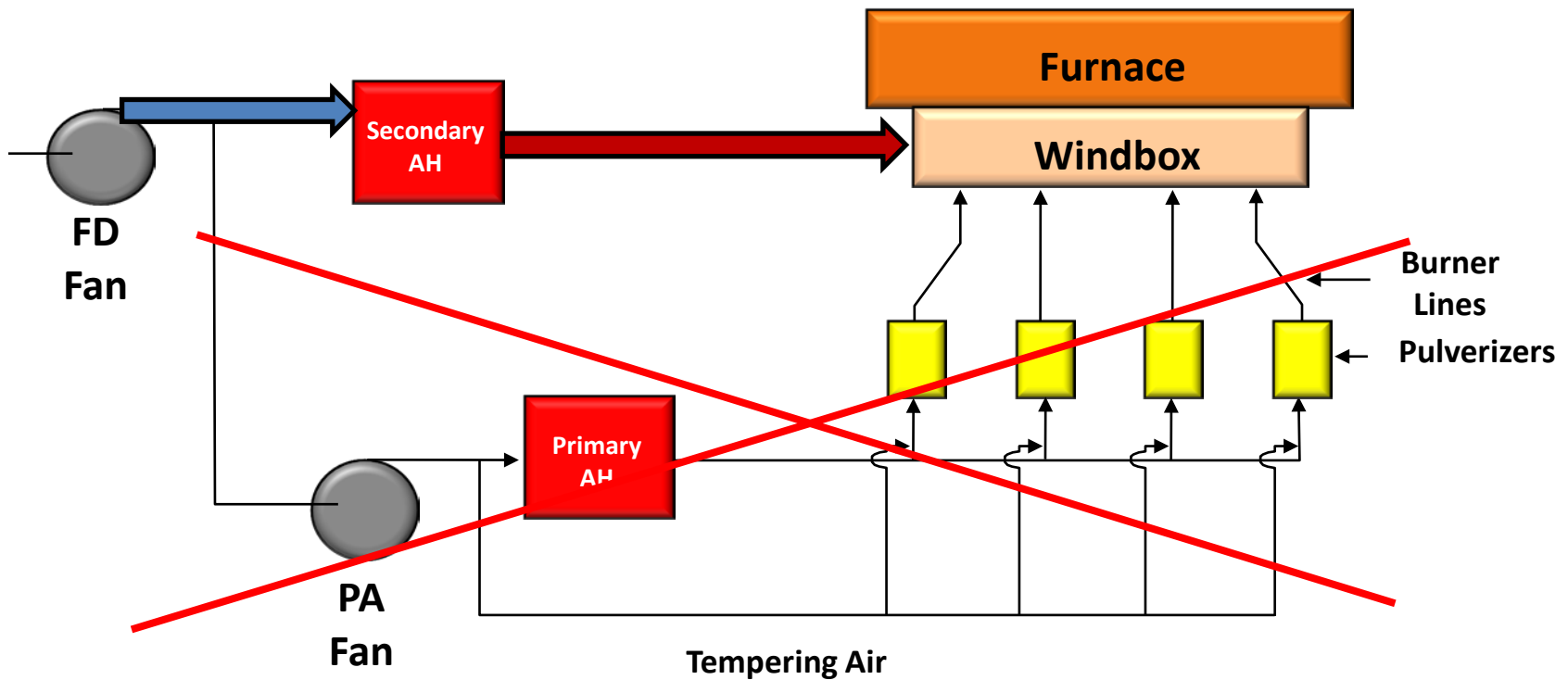

Natural Gas Conversion Boiler Considerations – Air Systems

Air System Considerations:

- ▶ After a gas conversion, all combustion air must be delivered by the FD fan through the existing **Secondary Air** ducts to the windbox and through the burners (and/or OFA system). Commonly the FD fan will have enough capacity but may not be able to deliver the higher static pressure.
- ▶ FGR will exacerbate the FD fan issues
- ▶ Due to shift in gas flow vs. air flows, the airheater balance should be checked. Airheater casing design pressure should also be checked.

Natural Gas Conversion Take Away Points

- **Different burner approaches depending on the owner's objectives**
- **Pressure Part Changes May Be Necessary**
 - To restore steam temperatures
 - To reduce spray flows
 - To address metallurgy issues
- **FD Fan Capabilities Will Need to be Reviewed**
- **There Are a Variety of Conversion Strategies**
- **Conversion Will Involve a Substantial Amount of Gas Piping and Valves**

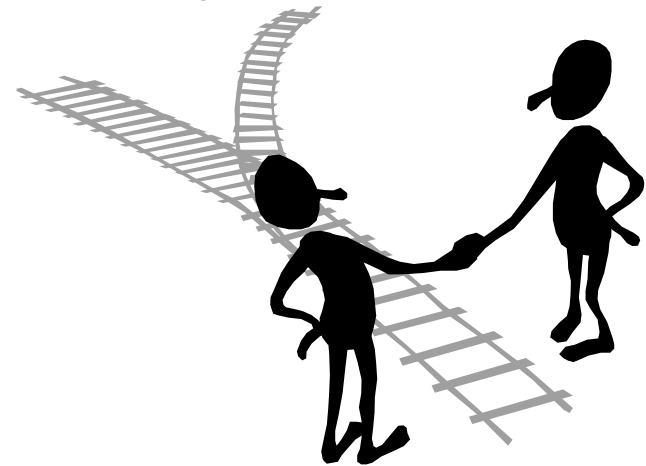

There Are No “Pat” Answers



Questions?

